

ONKYO SERVICE MANUAL

STEREO CASSETTE TAPE DECK MODEL TA-W460



Black and silver models

UDN, UDC, UD	120V AC, 60Hz
UG	220V AC, 50Hz
UW	120 or 220V AC, 50/60Hz
UQA, UQB	240V AC, 50Hz

SAFETY-RELATED COMPONENT WARNING!!

COMPONENTS IDENTIFIED BY MARK \triangle ON THE SCHEMATIC DIAGRAM AND IN THE PARTS LIST ARE CRITICAL FOR RISK OF FIRE AND ELECTRIC SHOCK. REPLACE THESE COMPONENTS WITH ONKYO PARTS WHOSE PART NUMBERS APPEAR AS SHOWN IN THIS MANUAL.

MAKE LEAKAGE-CURRENT OR RESISTANCE MEASUREMENTS TO DETERMINE THAT EXPOSED PARTS ARE ACCEPTABLY INSULATED FROM THE SUPPLY CIRCUIT BEFORE RETURNING THE APPLIANCE TO THE CUSTOMER.

SPECIFICATIONS

Track System:	4-tracks, 2-channels
Erasing System:	AC erase
Tape Speed:	4.8 cm/sec (1-7/8 i.p.s.)
Wow and Flutter:	0.07% (WRMS)
Frequency Response:	20 - 15,000Hz (Normal) (30 - 14,000Hz +3dB) 20 - 16,000Hz (High) (30 - 15,000Hz +3dB) 20 - 17,000Hz (Metal) (30 - 16,000Hz +3dB)
S/N Ratio:	Dolby NR off: 58dB (metal position tape) A noise reduction of 10dB above 5kHz and 5dB at 1kHz is possible with Dolby B NR. A noise reduction of 20dB at 5kHz is possible with Dolby C NR.
Input Jacks:	Microphone jack: 1 Input sensitivity: 0.6mV/ 600 ohms Input impedance: 2.7 kohms Line IN: 2 Input sensitivity: 60mV Input impedance: 50 kohms
Output:	Line OUT: 2 Standard output level: 500mV (0dB) Optimum load impedance: over 50 kohms

ONKYO[®]
AUDIO COMPONENTS

Motors: DC servo motor × 2; DC motor × 2
 Heads: REC/PB: Special Hard Permalloy × 2;
 Erase head: Ferrite × 1
 Power Supply: AC120V/60Hz
 Power Consumption: 19 watts
 Dimensions: 435(W) × 110(H) × 258(D)mm
 (17-1/8" × 4-3/8" × 10-1/8")
 Weight: 4.6 kg. (10.1 lbs.)

Specifications and external appearance are subject to change without notice because of product improvements.

SERVICE PROCEDURES

1. Replacement of power supply cord

There are two power supply cord outlets on the strainrelief. Insert them in prescribed direction to ensure safety. AS-UC-3 (UD<120V> model) should be inserted lengthwise and other types of cords should be inserted horizontally.

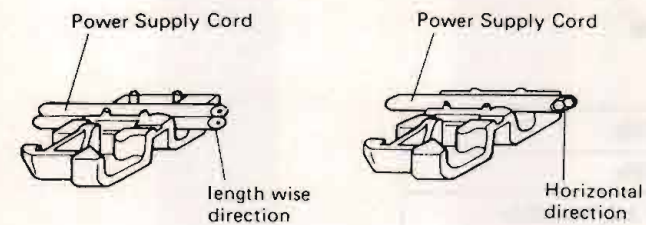

2. Instruction resistance measurement

Connect the insulating-resistance tester between the plug of power supply cord and chassis. Specifications; 500V more than 10MΩ

IC BLOCK DIAGRAM

IR2E02 (LEVEL METER DRIDE)

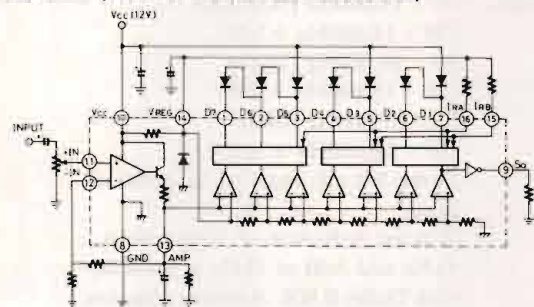

LBI287

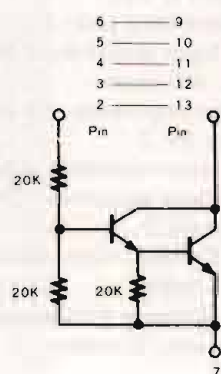

BA6251 (REC AMP. EQ. SW)

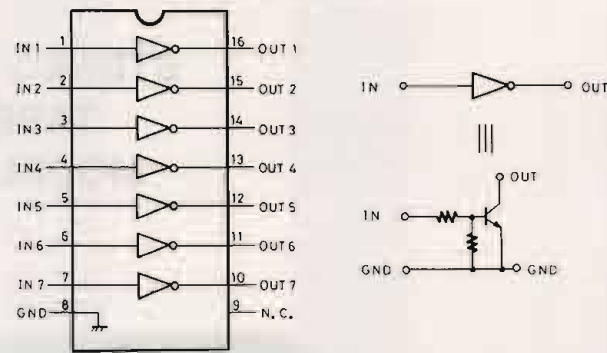

NJM-2068D-D

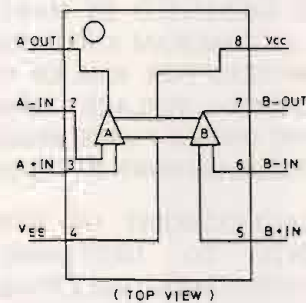
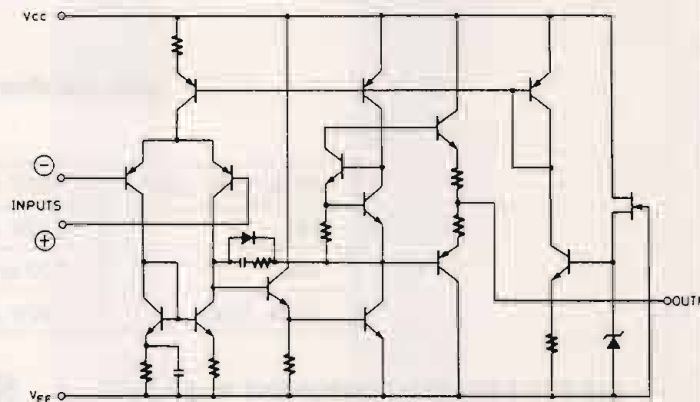

μPC1290C

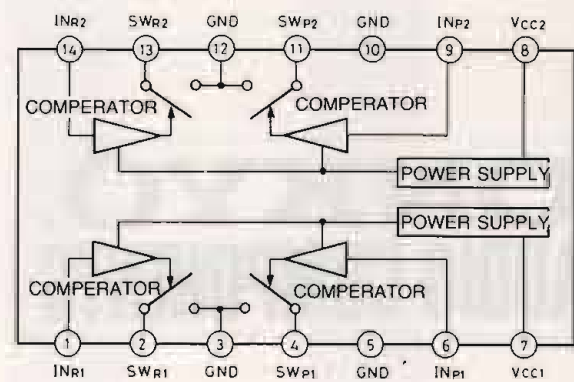

BLOCK DIAGRAM

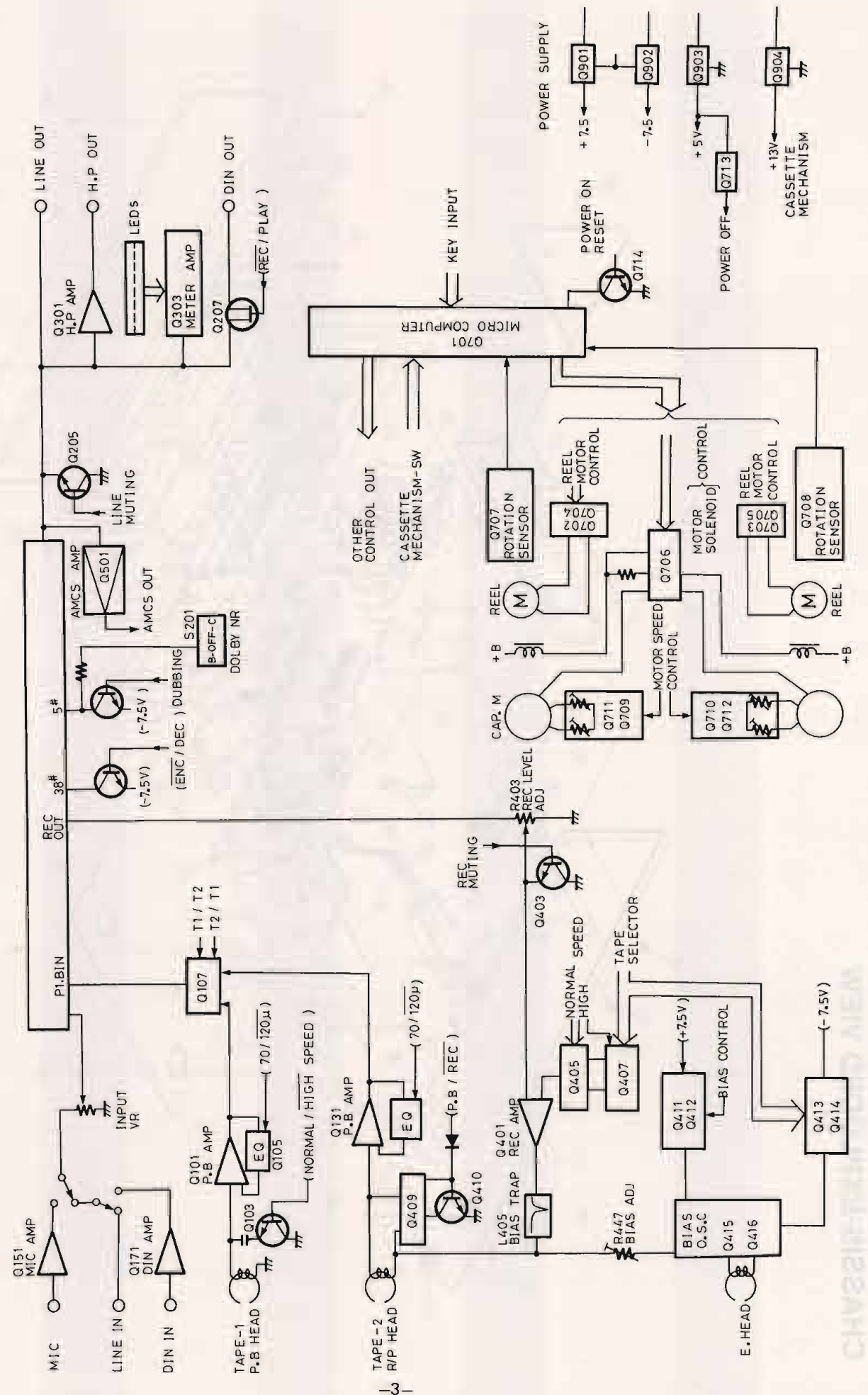

CHASSIS-EXPLODED VIEW

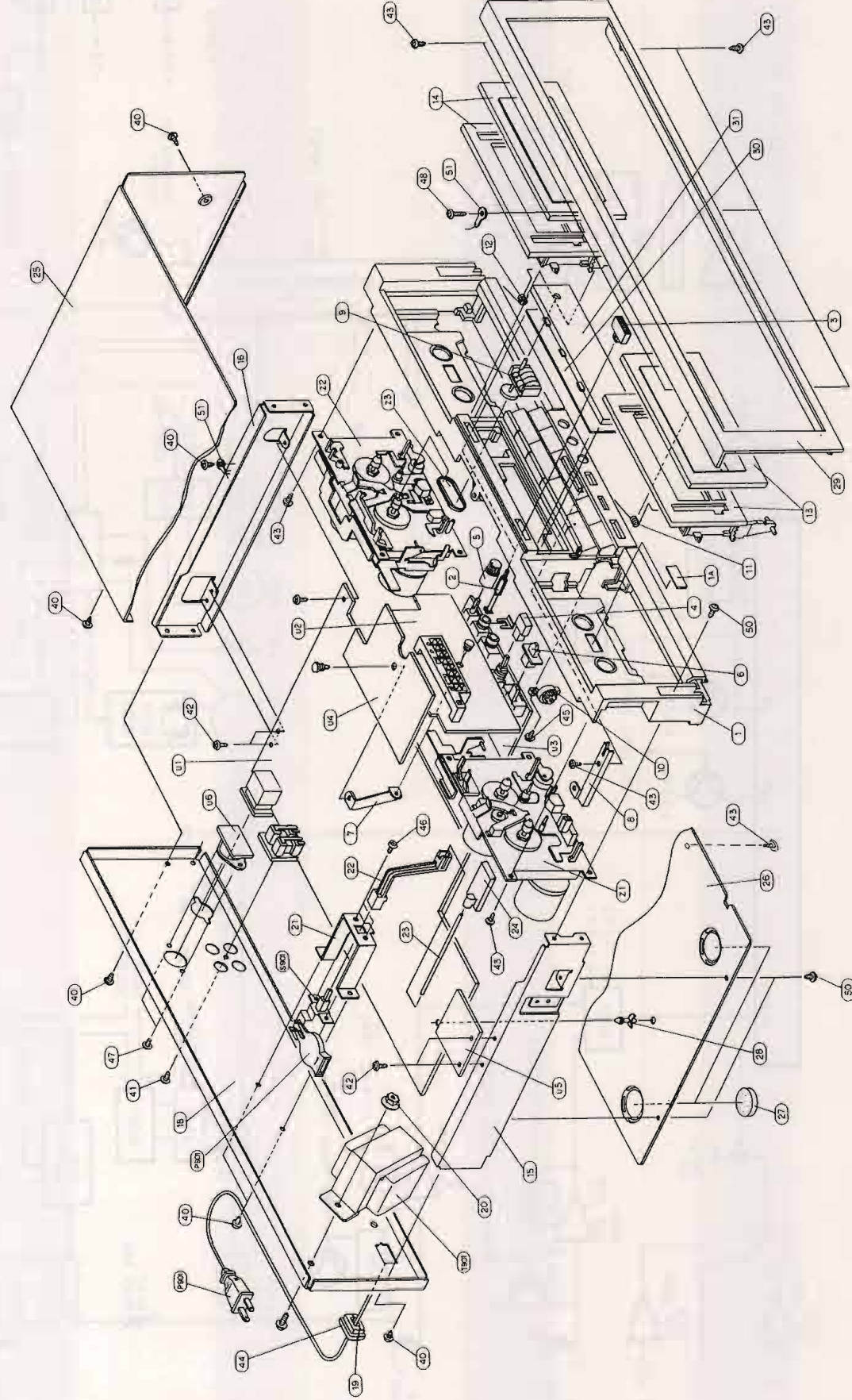

CHASSIS-EXPLODED VIEW PART LIST

REF. NO.	PART NO.	DESCRIPTION	REF. NO.	PART NO.	DESCRIPTION
1	27110319A	FRONT BRACKET (S)	40	834430068	TAP-TIGHT SCREW 3TTS×6BBC
	27110320A	FRONT BRACKET (B)	41	834430108	TAP-TIGHT SCREW 3TTS×10BB
1A	27262443	PLATE	42	831130088	TAP-TIGHT SCREW 3TTP×8B
2	27273042B	JOINT (EJECT)	43	833430088	TAP-TIGHT SCREW 3TTP×8PBC
3	28322838	KNOB (EJECT)	44	830440109	TAP-TIGHT SCREW 4TTC×10CBC
4	28322839A	KNOB (PUSH) (S)	45	833420108	TAP-TIGHT SCREW 2TTP×10BBC
	28322840A	KNOB (PUSH) (B)	46	82143006	PAN HEAD SCREW 3P×6FNBC
5	28322841	KNOB (VOL) (S)	47	82142604	PAN HEAD SCREW 2.6P×4FBC
	28322842	KNOB (VOL) (B)	48	834230108	TAP-TIGHT SCREW 3TTS×10NI
6	28322843A	KNOB (DOLBY) (S)	50	834430088	TAP-TIGHT SCREW 3TTS×8BBC
	28322844A	KNOB (DOLBY) (B)	51	223004-1	LUG
7	27141109	BRACKET (UP)	T901	2300184	NPT-951D, POWER TRANSFORMER (D)
8	27141110	BRACKET (D)		2300185	NPT-951G, POWER TRANSFORMER (G)
9	24601220	TAPE COUNTER		2300186	NPT-951DG, POWER TRANSFORMER (W)
10	28400282	DAMPER	P901	253099C	AS-UC-3, POWER SUPPLY CORD (D)
11	27180314	SPRING (T1)		253099C	AS-CEE, POWER SUPPLY CORD (G/W)
12	27180315	SPRING (T2)	S901	2513129A	NPS-111-L339P, POWER
13	28400300A	CASSETTE LID AS (T1)	S902	25035375	NSS-1258P, VOLTAGE SELECTOR (W)
13A	28400299A	CASSETTE LID (T1)	C901	25065123	DE7150FZ, 0.1μF, AC400V, CAPACITOR IS
13B	28400302A	WINDOW (T1)		3500065A	COVER
13C	27180272	SPRING (CA)(T1)	Z1	27300601	NDM-91, TAPE-1 MECHANISM ASS'Y
14	28400301A	CASSETTE LID AS (T2)	Z2	244099	NDM-92, TAPE-2 MECHANISM ASS'Y
14A	28400299A	CASSETTE LID (T2)		244100	ASS'Y
14B	28400303A	WINDOW (T1)	Z3	24602404	BELT(COUNTER)
14C	27180272	SPRING (CA)	U1	IN015504-1	NAAF-2904-1, MAIN CIRCUIT PCB BOARD
15	27115130E	SIDE BRACKET (R)		IN015504-1A	NAAF-2904-1A, MAIN CIRCUIT PCB BOARD (G/W)
16	27115169	SIDE BRACKET (L)	U2	IN015505-1	NADIS-2905-1, DISPLAY CIRCUIT PCB BOARD ASS'Y
17	880009	PLASTIC RIVET	U3	IN015506-1	PC BOARD ASS'Y
18	27120926B	BACK PANEL (D)		IN015506-1	NASW-2906-1, DOLBY SWITCH PCB BOARD ASS'Y
	27120927B	BACK PANEL (G)	U4	IN015507-1	NAETC-2907-1, MATER DRIVE PCB BOARD ASS'Y
	27120928B	BACK PANEL (W)	U5	IN015508-1	NAETC-2908-1, POWER SWITCH PCB BOARD ASS'Y
19	27300750	BUSHING (CORD)	U6	IN015509-1	TERMINAL PCB BOARD ASS'Y
20	86414010	FLANGE NUT FWN4×10FN			NAETC-2909-1, REMOTE CONTROL PCB BOARD ASS'Y
21	27141111	BRACKET (POW)			
22	27273064A	JOINT (POW)			
23	27260030	SHAFT			
24	28322845	KNOB (POW) (S)			
	28322846	KNOB (POW) (B)			
25	28184345	TOP COVER (S)			
	28322846	TOP COVER (B)			
26	28322846	TOP COVER (B)			
27	27170236	BOTTOM BOARD			
28	27175028	LEG			
29	27190011	HOLDER LCB-6			
	27210778A	FRONT PANEL (S)			
	27210779A	FRONT PANEL (B)			
30	28133174	BACK PLATE			
31	28191381	CLEAR PLATE			

NOTE: THE COMPONENTS IDENTIFIED BY MARK **A** ARE CRITICAL FOR RISK OF FIRE AND ELECTRIC SHOCK. REPLACE ONLY WITH PARTS NUMBER SPECIFIED.

NOTE: (D): Only 120V model
 (G): Only 220V model
 (W): Only Universal model
 (B): Only Black model
 (S): Only Silver model

PC BOARD PART LIST

MAIN CIRCUIT PC BOARD (NAAF-2904-1)

CIRCUIT NO.	PART NO.	DESCRIPTION
ics		
Q101	222956	NJM2068DD
Q107	222840661	4066B
Q131	222956	NJM2068DD
Q171	222917	NJM4558SD (G/W)
Q201	222910	HA12088NT
Q301	222652	M5218L
Q401	222465	NJM4558D
Q405	222840661	4066B
Q407, Q408	222918	BA6251
Q409	22240008	μPC1290C
Q501	222681 or 22240040	IR3702 or NJM2902N
Q701	22240028	HD614022S-F99
Q702, Q703	222775	BA6229
Q706	222698	LB1287
Q903	222780052	78M05
Transistors		
Q103-Q106, Q133, Q134	2211255, 2210746 or 2212485	2SC1815GR, 2SC945AP or JC501Q
Q202, Q203 Q205, Q206	221281 2212794, 2212795, 2211705 or 2211706	DTC114YS 2SD1468R, 2SD1468S, 2SD655E or 2SD655F
Q207, Q208	2211945 or 2212304	2SK246GR or (G/W) 2SK381D
Q403, Q404	2211255, 2210746 or 2212485	2SC1815GR, 2SC945AP or JC501Q
Q410 Q411	221281 2211255, 2210746 or 2212485	DTC114YS 2SC1815GR, 2SC945AP or JC501Q
Q412	2211454 or 2212494	2SA1015Y or JA101P
Q413, Q414 Q415, Q416 Q704, Q705 Q707, Q708	221281 2211544 221281 2211255, 2210746 or 2212485	DTC114YS 2SC1959Y DTC114YS 2SC1815GR, 2SC945AP or JC501Q
Q709, Q710 Q711, Q712	221281 2211945 or 221204	DTC114YS 2SK246GR or 2SK381D
Q713 Q714	2211454 or 2211255, 2210746 or 2212485	2SA1015Y or 2SC1815GR, 2SC945AP or JC501Q
Q901	2201594 or 2201595	2SD1189Q or 2SD1189R
Q902	2201275 or 2201276	2SB772Q or 2SB772P
Q904	2201285 or 2201286	2SD882Q or 2SD882P
Diodes		
D401	223163 or 223155	1SS133 or 1SS138
D402, D403	223163 or 223155	1SS133 or (G/W) 1SS138
D404-D708	223163 or 223155	1SS133 or 1SS138

D901	223890	W01RL
D902, D903	223894	1N4002F
D904, D905	2239552	RD8.2EB2
D906	2239671	RD15EB1
Coils		
L201, L202	233313 or 233306	NMC6048 or NMC6043
L203, L204	233372	NMC2029
L205	231126	NCH1182
L401, L402	231087	NCH-2135
L403, L404	231081	NCH2129
L405, L406	233314 or 233344	NCH2097 or NCH2114
OSC Block		
L407	231063	NLO-2037
Ceramic OSC		
X701	3010099	CSA4.00MG
Capacitors		
C107, C108	354721019	100μF, 6.3V, Elect.
C113, C114	354780229	2.2μF, 50V, Elect.
C135, C136	354721019	100μF, 6.3V, Elect.
C141, C142	354780229	2.2μF, 50V, Elect.
C171, C172	354741009	10μF, 16V, Elect. (G/W)
C175, C176	354780229	2.2μF, 50V, Elect. (G/W)
C201, C202	354744719	470μF, 16V, Elect.
C203-C206	354721009	10μF, 16V, Elect.
C211, C212	354786899	0.68μF, 50V, Elect.
C213, C214	354780229	2.2μF, 50V, Elect.
C221, C222	354786899	0.68μF, 50V, Elect.
C223, C224	354780229	2.2μF, 50V, Elect.
C225, C226	354741009	10μF, 16V, Elect.
C227	354742209	22μF, 16V, Elect.
C403, C404	354744709	47μF, 16V, Elect.
C405, C406	354782299	0.22μF, 50V, Elect.
C407, C407	354741009	10μF, 16V, Elect.
C435	370131234S	0.012μF, 100V, APS.
C438	354741009	10μF, 16V, Elect.
C439	354741019	100μF, 6.3V, Elect.
C504	354780229	2.2μF, 50V, Elect.
C701	354724719	470μF, 6.3V, Elect.
C703	352741009	10μF, 16V, Elect.
C706, C708	352942206S	22μF, 16V, NP
C710	354780479	4.7μF, 50V, Elect.
C711	352741009	10μF, 16V, Elect.
C903	354751029	1000μF, 25V, Elect.
C904	354761019	100μF, 35V, Elect.
C905, C906	354741019	100μF, 16V, Elect.
C907	354751029S	1000μF, 25V, Elect.
C908	354761019	100μF, 35V, Elect.
C909, C910	354741019	100μF, 16V, Elect.
C911	3504168	13000μF, 25V, Elect.
C912	354786899	0.68μF, 50V, Elect.
C913, C914	354741019	100μF, 16V, Elect.
Resistors		
R113, R114	5210062	N06HR4.7kBD, Semifixed
R141, R142	5210062	N06HR4.7kBD, Semifixed
R403, R404	5210068	N06HR47kBD, Semifixed
R447, R448	5210070	N06HR100kBD, Semifixed
R724, R728	5210062	N06HR4.7kBD, Semifixed
R732, R736	5210062	N06HR4.7kBD, Semifixed
R451	442522714	270Ω, 1/2W, Oxidefilm
R452	442523304	33Ω, 1/2W, Oxidefilm
R453	442521814	180Ω, 1/2W, Oxidefilm
R454	442523304	33Ω, 1/2W, Oxidefilm

R738	441723304	33Ω, 2W, Oxidefilm
R739, R740	442522204	22Ω, 1/2W, Oxidefilm
R701-R704	49163392404	3.9kΩ×4, 1/10W, Network
R723, R727	4000112	TDS-A090D, Thermistor
R731, R735	4000112	TDS-A090D, Thermistor
R901, R904	442521004	10Ω, 1/2W, Oxidefilm
R902, R905	442523314	330Ω, 1/2W, Oxidefilm
R907	442520104	1Ω, 1/2W, Oxidefilm
R908	442523314	330Ω, 1/2W, Oxidefilm

Miscellaneous

P201	25045142	NPJ-4PDBL55, input/output Terminal
P202	25050064	NSCT-5P18, DIN socket (G/W)
P101	25055133	NPLG-3P-117, Plug
P102	25055136	NPLG-6P-120, Plug
P103	25055132	NPLG-2P-116, Plug
P701	2000618	NSAS-14P574, Socket
P702	2000619	NSAS-14P575, Socket
	27160029	RAD-07, Radiator
	27160166	Radiator (Q702, Q703)
	82143006	3P+6FN(BC), Screw
	27150189	Shield plate

DISPLAY CIRCUIT PC BOARD (NADIS-2905-1)

CIRCUIT NO.	PART NO.	DESCRIPTION
Leds		
D301-D305	225137CG, 225137DG or 225137DY	SEL2413ECG, SEL2413EDG or SEL2413EDY
D306-D308 D309-D313	225141 225137CG, 225137DG or 225137DY	SEL2213C SEL2413ECG, SEL2413EDG or SEL2413EDY
D314-D316 D708-D709	225141 225137CG, 225137DG or 225137DY	SEL2213C SEL2413ECG, SEL2413EDG or SEL2413EDY
D710, D711 D712, D713	225141 225141	SEL2213C SEL2213C
Switch		
S702-S715	25035548	NPS-111-S510, Push switch
Miscellaneous		
P601	25055263	NPLG-3P246, Plug
P603, P604	25050325 27190509	NSCT-20P152, Socket Holder (LED)

DOLBY SWITCH CIRCUIT PC BOARD (NASW-2906-1)

CIRCUIT NO.	PART NO.	DESCRIPTION
IC		
Q151	222465	NJM-4558D
Capacitors		
C151, C155	354786899	0.68μF, 50V, Elect.
C156, C157	354741009	10μF, 50V, Elect.
Resistors		
R193, R194	51044198	N09RGM50KA, Input VR.
Switches		
S201	25065312	NSS-23121
S701	25035428	NPS-122-L392, Push
Terminals		
P151	25045130	HLJ4308-01-010, Mic.
P301	25045187	HLJ0541-01-010, Headphon

MATER DRIVE PC BOARD (NAETC-2907-1)

CIRCUIT NO.	PART NO.	DESCRIPTION
ics		
Q303, Q304	222623	IR2E02
Capacitors		
C301, C302	354780479	4.7μF, 50V, Elect.
C303, C304	354780109	1μF, 50V, Elect.
Plug		
P605, P606	25055306	NPLG-20P289

REMOTE CONTROL PC BOARD (NAETC-2909-1)

CIRCUIT NO.	PART NO.	DESCRIPTION
P710	25050070	NSCT-7P20, DIN

NOTE: (G): Only 220V model
(W): Only Universal model

ADJUSTMENT PROCEDURES

PRECAUTIONS

- Before adjustment, clean the following parts with an alcohol moistend swab.
 - * record/playback head
 - * pinch roller
 - * erase head
 - * capstan
- Do not use magnetized screwdriver for adjustments.
- Demagnetize record/playback head with a head demagnetizer.

TEST EQUIPMENT/TOOLS REQUIRED:

Audio oscillator
Digital frequency counter

Oscilloscope
Attenuator
AC voltmeter
Non-magnetic screw driver
Blank tapes (completely erased)
 NORMAL NEW UD90
 HIGH NEW XL-II90
 METAL NEW MX60
 Test tapes
 VTT-658 : 10 KHz, -15dB
 MTT-111 : 3 kHz, -10dB
 MTT-150 : Dolby level calibration
 400Hz, tone 200nWb/m

Item	Connection of instrument	Line input	Test tape	Mode	Output indicator	Adjustment point	Adjust	Remarks		
1	Frequency counter to LINE output terminal		MTT-111	T-1 H. speed	PB	Frequency counter	Semi-fixed R728	6,040±10Hz	High speed connect the TP-3 to GND	
				N. speed			R724	3,020±5Hz		
				T-2 H. speed			PB	Semi-fixed R736	6,000±10Hz	High speed connect the TP-4 to GND
				N. speed			PB	R732	3,000±5Hz	
2	AC voltmeter and oscilloscope to LINE output terminal		VTT-658	PB	AC voltmeter	Head azimuth screw	Maximum and same phase at channels L and R	See fig. 1		
3	AC voltmeter to terminals TP-1 and TP-2		MTT-150	PB	AC voltmeter	T-1 R-113, R-114 T-2 R-141, R-142	300mV			
4	Fig. 2	1kHz, -20dB and 12kHz, -20dB	NEW XL-II90	T-2 REC/PB	AC voltmeter	R-447 (Ch.L) R-448 (Ch.R)	Same level at REC/PB	Input VR maximum		
5	Fig. 2	1kHz		REC PAUSE	AC voltmeter	Attenuator or AF OSC output	350mV	Input VR maximum		
				REC/PB	AC voltmeter	R-403 (Ch.L) R-404 (Ch.R)	Same level at REC/PB			

PLAY torque 30 - 70g/cm
 FF.REW torque 70 - 160g/cm
 Back tention 1.5 = 5g/cm

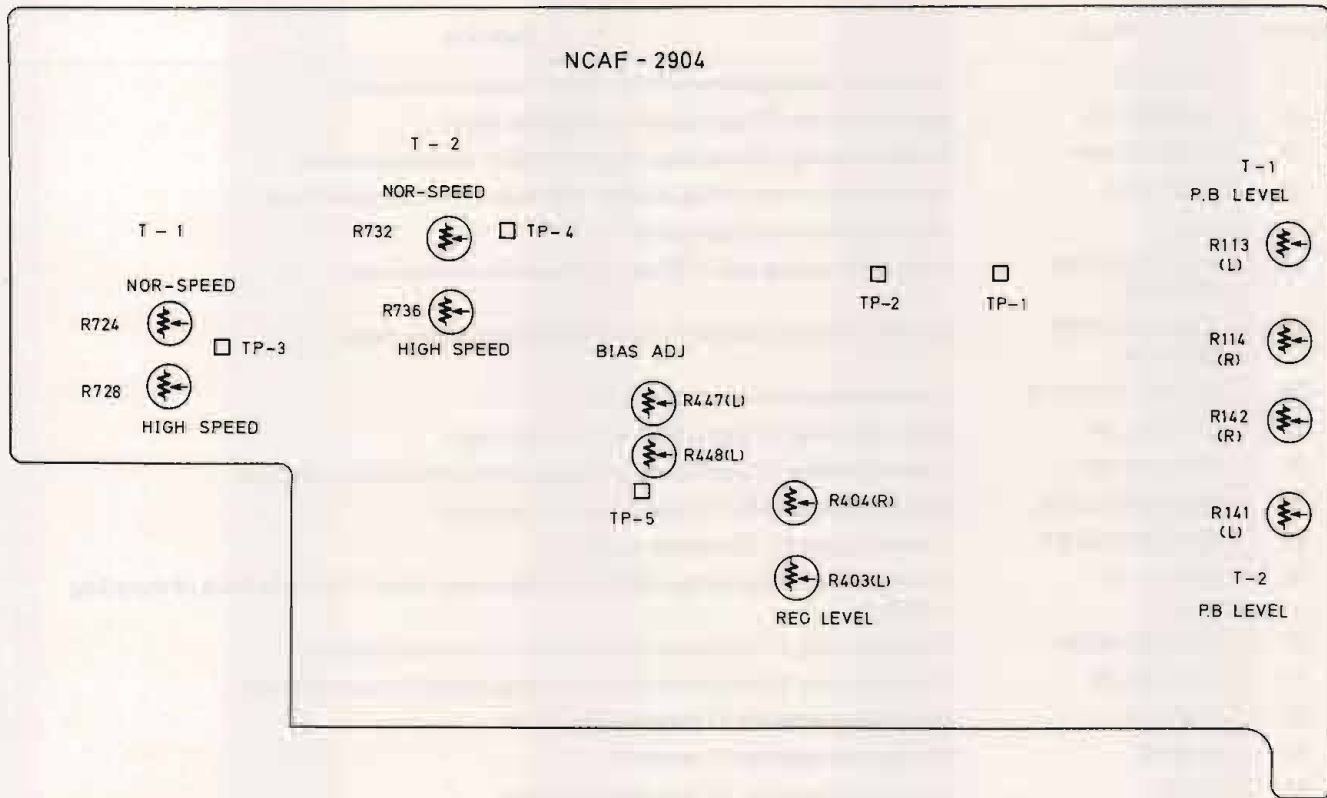

IC BLOCK DIAGRAM

HA12088NT
(DOLBY NR IC 2CH in one package)

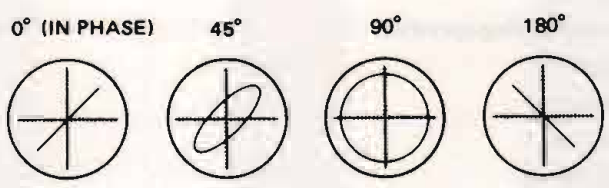
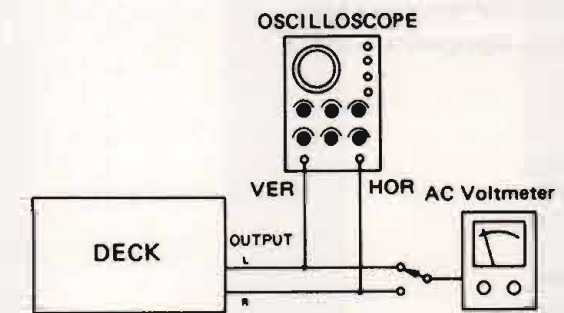
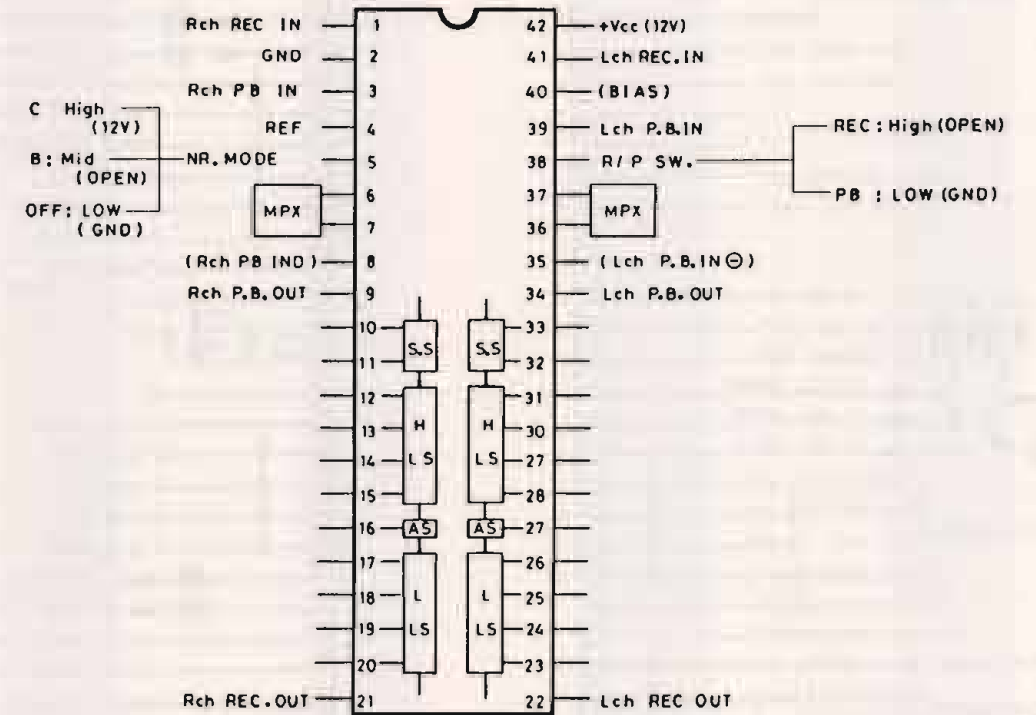

Confirming phase relationship

fig-1

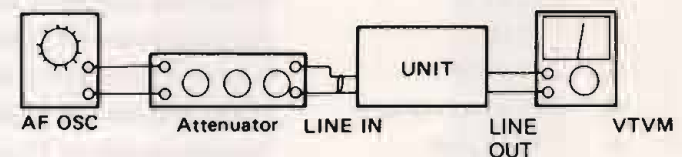
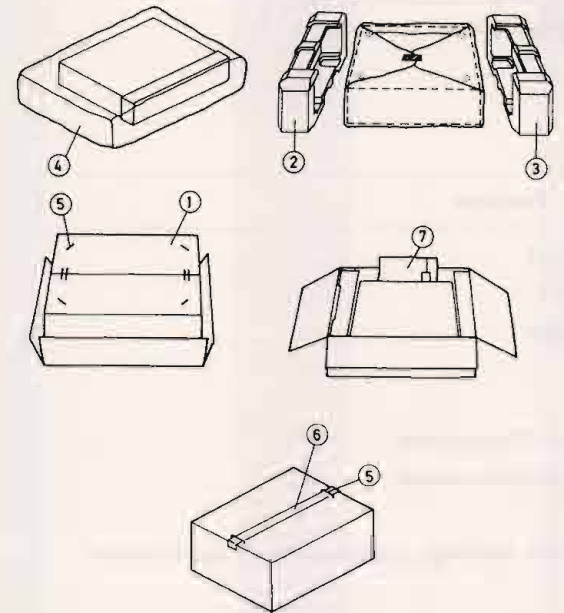

fig-2

PACKING VIEW



NOTE
(N): Only U.S.A. Model
(W): Only 120/220V Model
(S): Silver Model
(B): Black Model

PACKING PART LIST

D Model		
REF NO.	PART NO.	DESCRIPTION
1	29051440	Master carton box (S)
	29051441A	Master carton box (B)
2	29090987	Pad(L)
3	29090988	Pad(R)
4	29100037A	650×500 Poly bag
	29095012-1	500×800 protection sheet(B)
5	282301	Sealing hook
6	260012	Damplon tape
7		Accessory bag ass'y
	29341092	Instruction manual
	2010098	Connection cable
	29365019	Waranty card (N)
	29358002E	Service station list (N)
	29100006A	350×250 Poly bag

G/W Model		
REF NO.	PART NO.	DESCRIPTION
1	29051440	Master carton box (S)
	29051441A	Master carton box (B)
2	29090987	Pad(L)
3	29090988	Pad(R)
4	29100037A	650×500 Poly bag
	29095012-1	500×800 protection sheet(B)
5	282301	Sealing hook
6	260012	Damplon tape
7		Accessory bag ass'y
	29341096	Instruction manual
	2010098	Connection cable
	25055018	Conversion plug (CV-K-1)(W)
	29100006A	350×250 Poly bag

MICRO COMPUTER HD614022S-F99

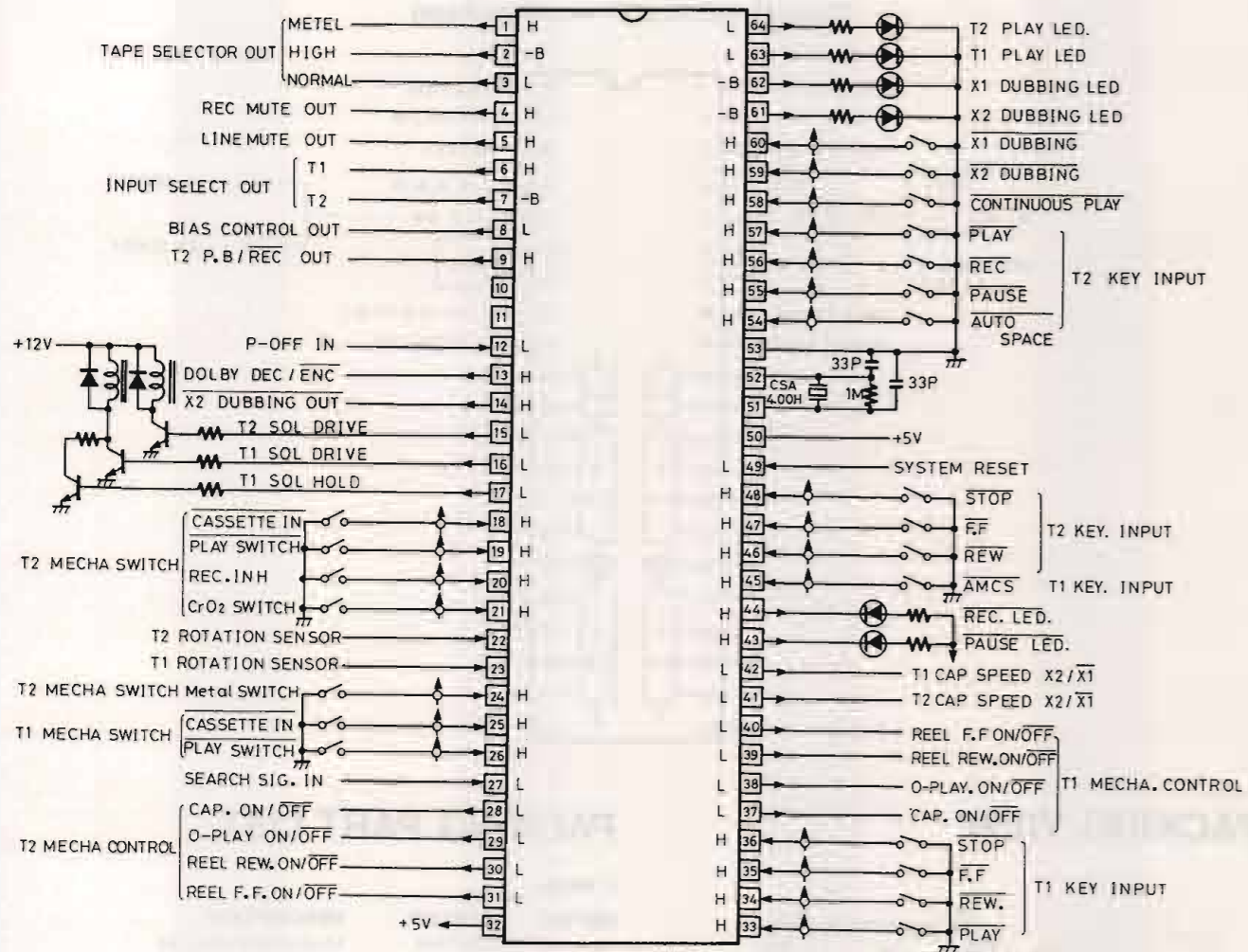

Pin No.	Name	Function
1	METAL	Outputs tape type; With metal tape. logic 1
2	HIGH	Outputs tape type; With high tape. logic 1
3	NORMAL	Outputs tape type; With normal tape. logic 1
4	REC MUTE	Output used for muting recording
5	LINE MUTE	Output used for muting line
6	INPUT SEL. T1	Input signal selection output; with logic 1, T1 is selected.
7	INPUT SEL. T2	Input signal selection output; with logic 1, T2 is selected.
8	BIAS CONT.	Bias oscillator control output
9	T2 PB/REC	T2 recording/playback change-over output; with logic 1, playback; with logic 0, record
10	TIMER REC	Switch input for recording timer
11	TIMER PB	Switch input for playback timer
12	P OFF	Input for detecting power cutoff
13	DECODE/ENCODE	Output for Dolby IC Encode/Decode change-over; with logic 1, decode
14	X2 DUBB. OUT	Indicating output for high speed dubbing mode (negative logic)
15	T2 SOL.	Solenoid drive output for T2
16	T1 SOL.	Solenoid drive output for T1

Pin No.	Name	Function
17	T1 HOLD	Output for holding solenoid when T1 music selection is made
18	T2 CASS. IN	Input indicating T2 tape is loading (negative logic)
19	T2 PLAY SW	Input indicating T2 head base is at playback or recording position
20	REC. INH	Input to prevent recording in error; with logic 1, recording inhibited
21	CrO ₂	Detecting input for high type in T2
22	T2 ROTATION SENSOR	Used for detecting end of T2 tape; reel holder rotation input
23	T1 ROTATION SENSOR	Used for detecting end of T1 tape; reel holder rotation input
24	METAL SWITCH	Detecting input for metal tape in T2
25	T1 CASS. IN	Input indicating T1 tape is loading (negative logic)
26	T1 PLAY SW	Input indicating T1 head base is at playback or music selection position
27	SEARCH SIG IN	Search signal input for T1 music selection operation
28	T2 CAP ON/OFF	Control output for T2 capstan motor
29	T2 O PLAY	Control of reel motor torque with indicating output when T2 is in playback or recording condition
30	T2 REEL REW	Output causing T2 reel motor to rotate in the rewinding direction
31	T2 REEL FF	Output causing T2 reel motor to rotate at high speed forward direction
33	T1 PLAY	Designating input for T1 playback operation
34	T1 REW	Designating input for T1 rewind
35	T1 FF	Designating input for T1 high speed forward
36	T1 STOP	Designating input for all operation of T1 stopped
37	T1 CAP ON/OFF	Control output for T1 capstan motor
38	T1 O PLAY	Control of reel motor torque with indicating output when T1 is in playback or recording condition
39	T1 REEL REW	Output causing T1 reel motor to rotate in the rewinding direction
40	T1 REEL FF	Output causing T1 reel motor to rotate at high speed forward direction
41	T2 CAP X2/X1	Speed control output for T2 capstan motor; high speed with logic 1
42	T1 CAP X2/X1	Speed control output for T1 capstan motor; high speed with logic 1
43	T2 PAUSE LED	LED output for T2 pause display
44	T2 REC LED	LED output for T2 record display
45	T1 AMCS	Designating input for T1 AMCS operation
46	T2 REW	Designating input for T2 rewind
47	T2 FF	Designating input for T2 fast forward
48	T2 STOP	Designating input to stop all T2 operation
54	T2 AUTO SPACE	Designating input for T2 auto space operation
55	T2 PAUSE	Designating input for T2 pause or recording pause operation
56	T2 REC	Designating input for T2 recording
57	T2 PLAY	Designating input for T2 playback or recording operation
58	CONTINUOUS PLAY	Continuous playback detection input
59	X2 DUBBING	Designating input for high speed dubbing
60	DUBBING	Designating input for dubbing operation
61	X2 DUBBING LED	LED output for high speed dubbing display
62	DUBBING LED	LED output for dubbing operation display
63	T1 PLAY LED	LED output for T1 play display
64	T2 PLAY LED	LED output for T2 play display

PC BOARD VIEW FROM BOTTOM SIDE

NAFF-2904

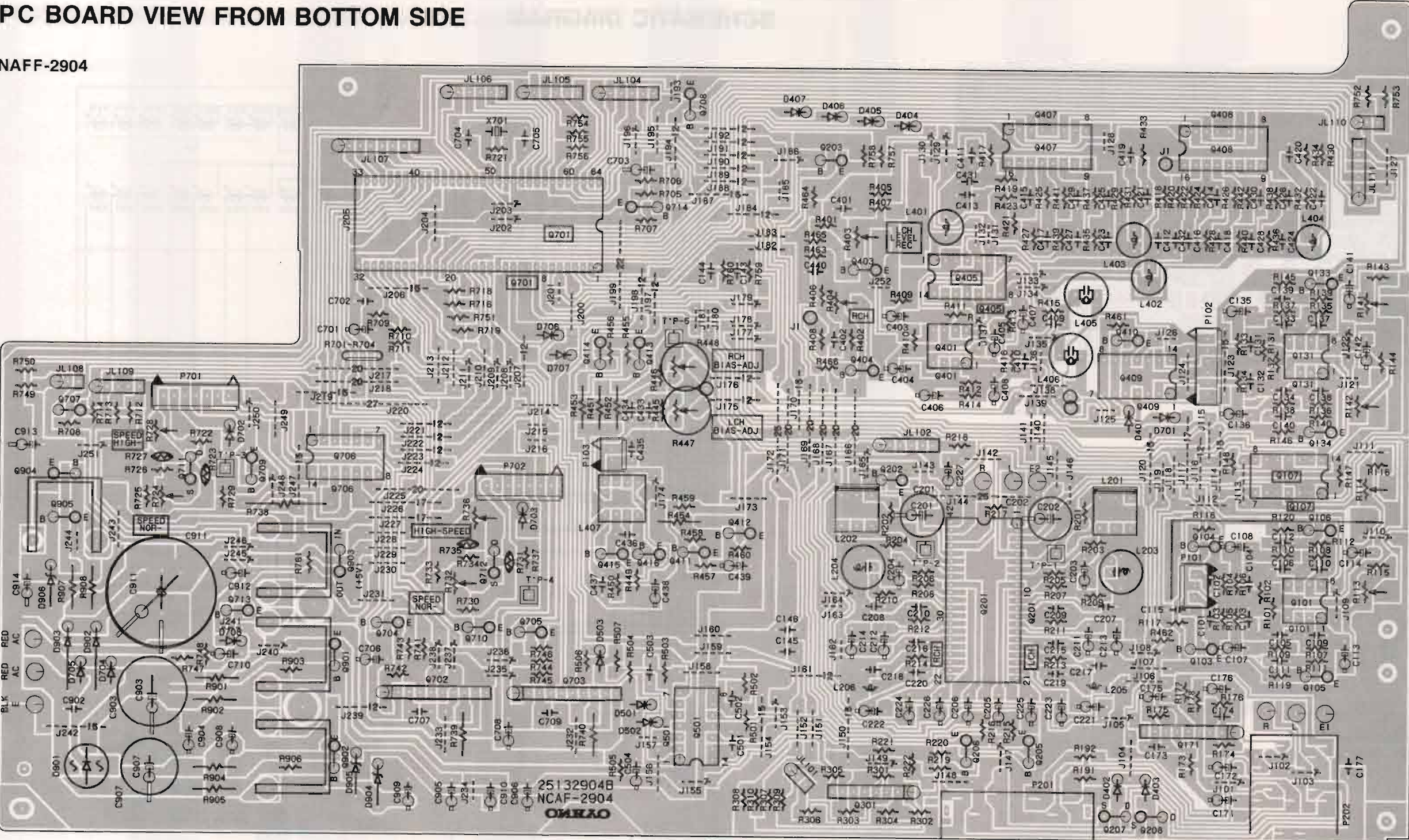

NASW-2906

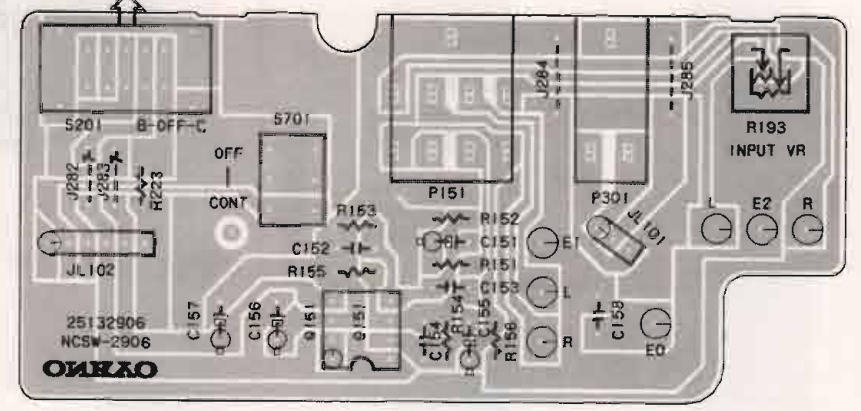

SCHEMATIC DIAGRAM

NADIS-2905

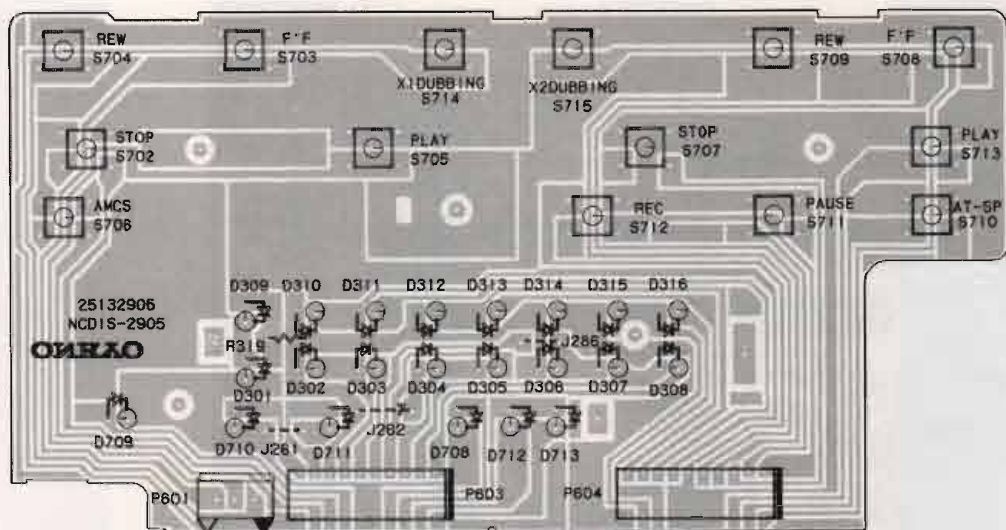

NAETC-2907

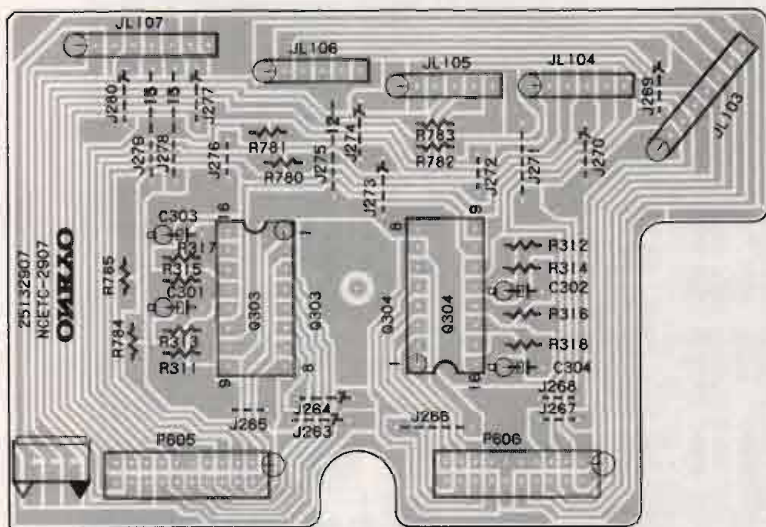

NAETC-2908

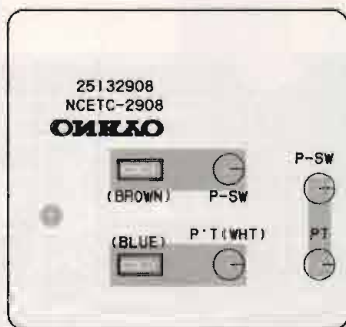

NAETC-2909

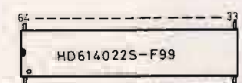
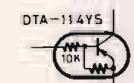
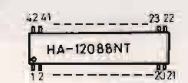
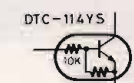
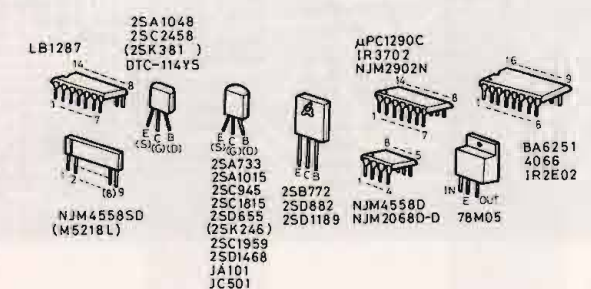
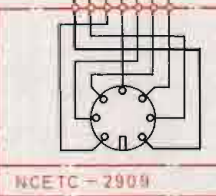
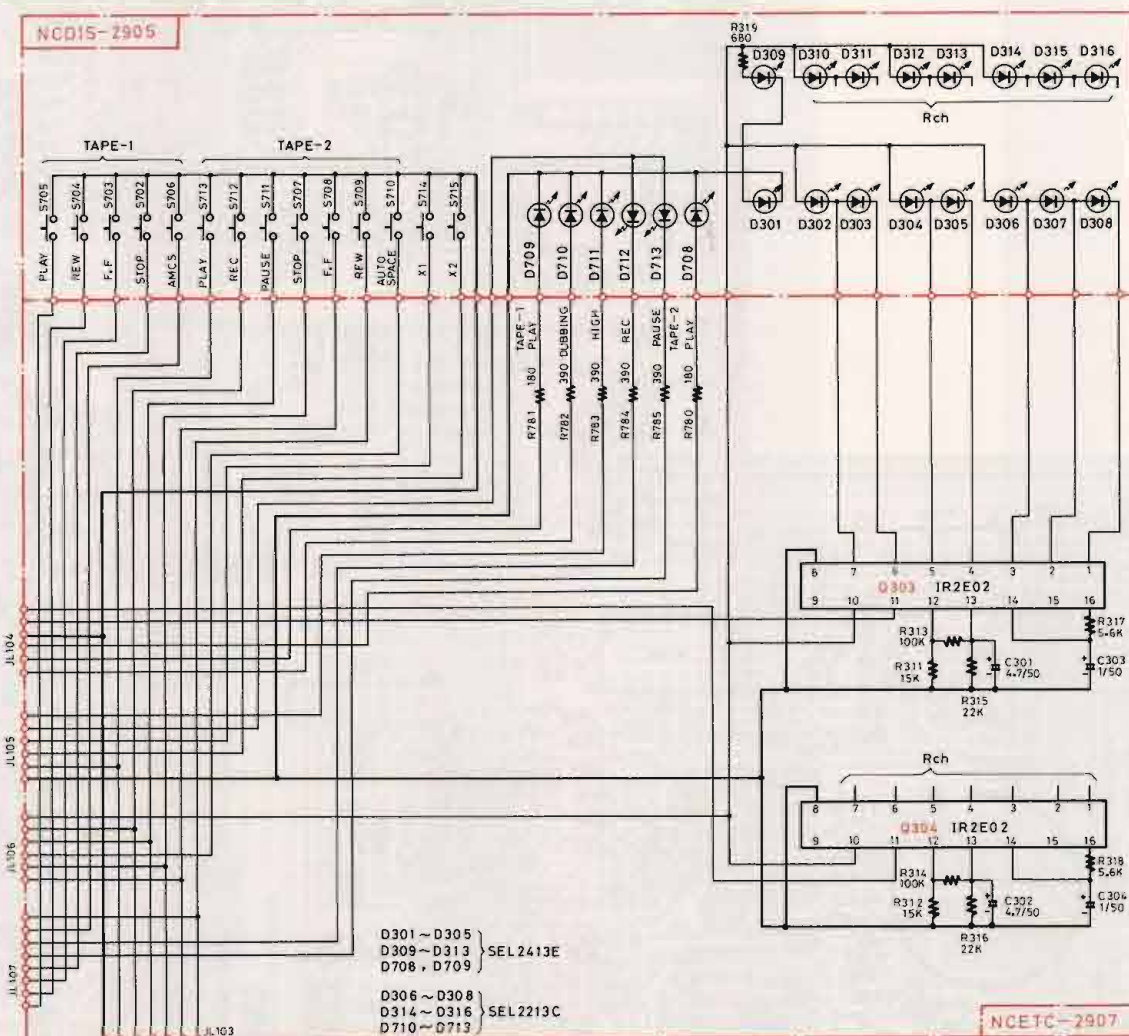

- NOTES
- ALL RESISTORS ARE IN OHMS 1/4WATTS or 1/6WATTS UNLESS OTHERWISE NOTED.
 - ALL CAPACITORS ARE IN μF/50V UNLESS OTHERWISE NOTED.
 - ELECTROLYTIC CAPACITORS(=E) ARE IN μF/ WV.
 - ALL DIODES ARE 1SS133 UNLESS OTHERWISE NOTED.
 - VOLTAGE(MEASURED WITH V.T.V.M) ≡ V IS DC VOLTAGE. (STOP MODE)
 - THE COMPONENTS IDENTIFIED BY MARK Δ ARE CRITICAL FOR SAFETY. REPLACE ONLY WITH PART NUMBER SPECIFIED.

SCHEMATIC DIAGRAM

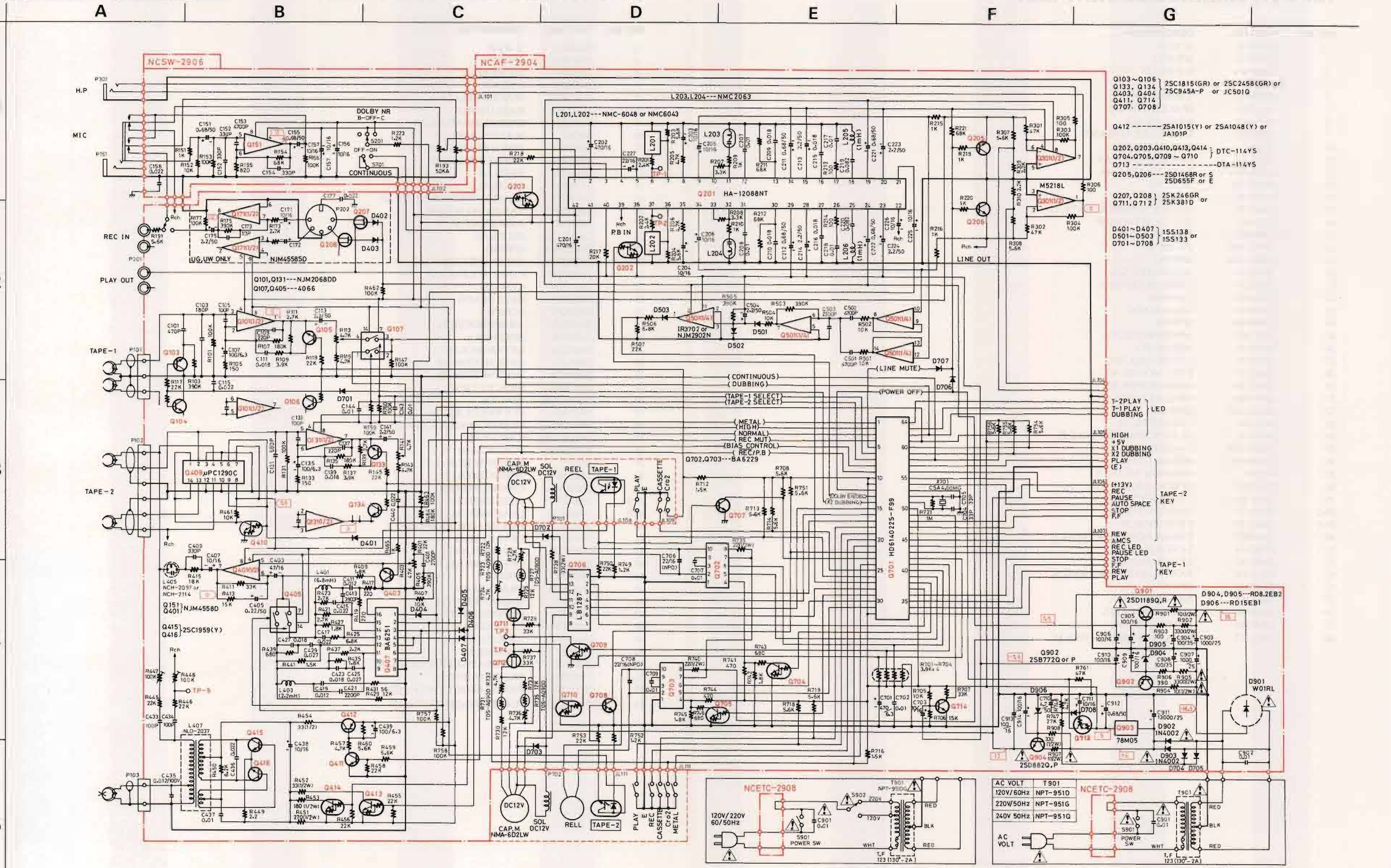

- Q103~Q106 } 2SC1815(GR) or 2SC2458(GR) or
- Q133, Q134 } 2SC945A-P or JC501Q
- Q403, Q404 } 2SC945A-P or JC501Q
- Q411, Q714 } 2SC945A-P or JC501Q
- Q708 } 2SC945A-P or JC501Q

- Q412 ----- 2SA1015(Y) or 2SA1048(Y) or JA101P

- Q202, Q203, Q410, Q413, Q414 } DTC-114YS
- Q704, Q705, Q709 ~ Q710 } DTC-114YS
- Q713 ----- DTA-114YS
- Q205, Q206 --- 2SD1468R or S 2SD655F or E

- Q207, Q208 } 2SK246GR
- Q711, Q712 } 2SK381D or

- D401~D407 } 1SS138
- D501~D503 } 1SS133 or
- D701~D708 } 1SS133 or

- T-2PLAY LED
- T-1PLAY LED
- DUBBING LED
- HIGH +5V
- X1 DUBBING
- X2 DUBBING
- PLAY (E)
- (+13V) REC PAUSE AUTO SPACE STOP F.F. REW PLAY
- TAPE-2 KEY
- TAPE-1 KEY

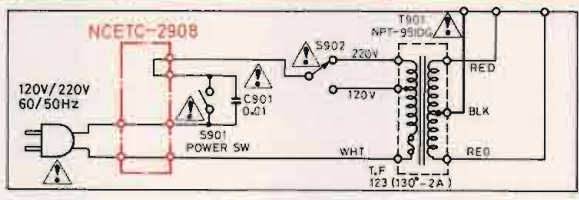
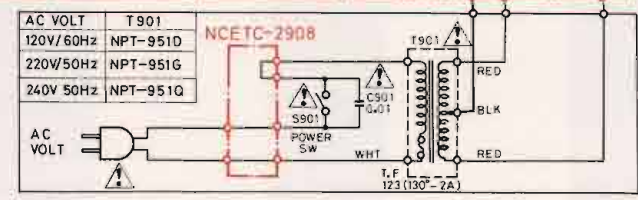

TAPE (1) MECHANISM-PART LIST

REF.NO.	PART NO.	DESCRIPTION
1	801291A	SCREW
2	24605652	SPRING
4	24600066	R/P HEAD
5	893030	E-3
6	24600048	TAPE GUIDE
7	24611302	SPACER (HEAD)
8	24611303	BASE (HEAD)
9	24605584	SPRING (HEAD BASE)
10	801382	WAVE SCREW
11	24602414	PINCH ROLLER AS
12	24602419	TAKE UP REEL AS
13	24602403	REEL AS
14	24610926	OIL SEAL
15	24611175	PLASTIC WASHER 2.1×7×.25
16	24611305	TAP-TIGHT SCREW
17	24607067	ARM (PLAY) F
18	24602342A	IDLER AS
19	24605588A	SPRING
20	24606273	SOLENOID COIL
21	24606274	CORE (SOLENOID)
22	24611304	CHASSIS
23	24602420	BELT (MAIN)
24	24609006	SCREW
25	24607065	ARM (PROTECT)
26	24605595	SPRING (R)
27	24603326	LEVER (HOLD) C
28	24601227	REEL MOTOR AS
29	24601228	MAIN MOTOR AS
31	24607068	BRACKET (FW)
32	24604076A	SPACER
33	24602401	FLYWHEEL AS
34	24611041	PLASTIC WASHER 2.6×0.25
35	24602417A	CAM GEAR
36	838126080	SCREW 2.6×8
37	801355	SCREW/W M2.6×3.5
38	24605587	SPRING (HOLD)
39	24606268	CONNECTOR AS
39-2	24606271	PUSH SWITCH
39-5	24606270	LEAF SWITCH
40	24609007	PAN HEAD SCREW TT3×4.5
41	24603344	LEVER (REC)
42	24603345	LEVER (PLAY)
43	24611306	PAN HEAD SCREW 2.6×6ZN
44	24605653	SPRING
45	24611185	BRACKET AS
46	24605596	SPRING (EJECT) L
47	24603331	LEVER (EJECT)
48	24611177	PLASTIC WASHER 1.7×0.25

TAPE (2) MECHANISM-PART LIST

REF.NO.	PART NO.	DESCRIPTION
1	801291A	SCREW
2	24605652	SPRING
4	24600067	R/P HEAD
6	24600032	E HEAD
7	24611302	SPACER (HEAD)
8	24611303	BASE (HEAD)
9	24605584	SPRING (HEAD BASE)
10	801382	WAVE SCREW
11	24602414	PINCH ROLLER AS
12	24602419	TAKE UP REEL AS
13	24602340	REEL AS
14	24610926	OIL SEAL
15	24611175	PLASTIC WASHER 2.1×7×.25
16	24611305	TAP-TIGHT SCREW
17	24607067	ARM (PLAY) F
18	24602342A	IDLER AS
19	24605588A	SPRING
20	24606273	SOLENOID COIL
21	24606274	CORE (SOLENOID)
22	24611304	CHASSIS
23	24602420	BELT (MAIN)
24	24609006	SCREW
25	24607069	ARM (PROTECT)
26	24605586	SPRING (L)
27	24603326	LEVER (HOLD) C
28	24601227	REEL MOTOR AS
29	24601228	MAIN MOTOR AS
31	24607068	BRACKET (FW)
32	24604076A	SPACER
33	24602401	FLYWHEEL AS
34	24611041	PLASTIC WASHER 2.6×0.25
35	24602417A	CAM GEAR
36	838126080	SCREW 2.6×8
37	801355	SCREW/W M2.6×3.5
38	24605587	SPRING (HOLD)
39	24606272	CONNECTOR AS
39-2	24606271	PUSH SWITCH
39-5	24606270	LEAF SWITCH
40	24609007	PAN HEAD SCREW TT3×4.5
41	24603344	LEVER (REC)
42	24603345	LEVER (PLAY)
43	24603346	LEVER (METAL)
44	24605653	SPRING
45	24611183	BRACKET AS
46	24605592	SPRING (EJECT) L
47	24603331	LEVER (EJECT)
48	24611190	BRACKET AS
49	24607070	ARM (EJECT) A
50	893030	E WASHER 3
51	24609002	PAN HEAD SCREW SW2×4ZN
52	24602404	BELT (COUNTER)
53	24611306	PAN HEAD SCREW 2.6×6ZN
54	24611177	PLASTIC WASHER 1.7×0.25

TAPE (1) MECHANISM-EXPLODED VIEW

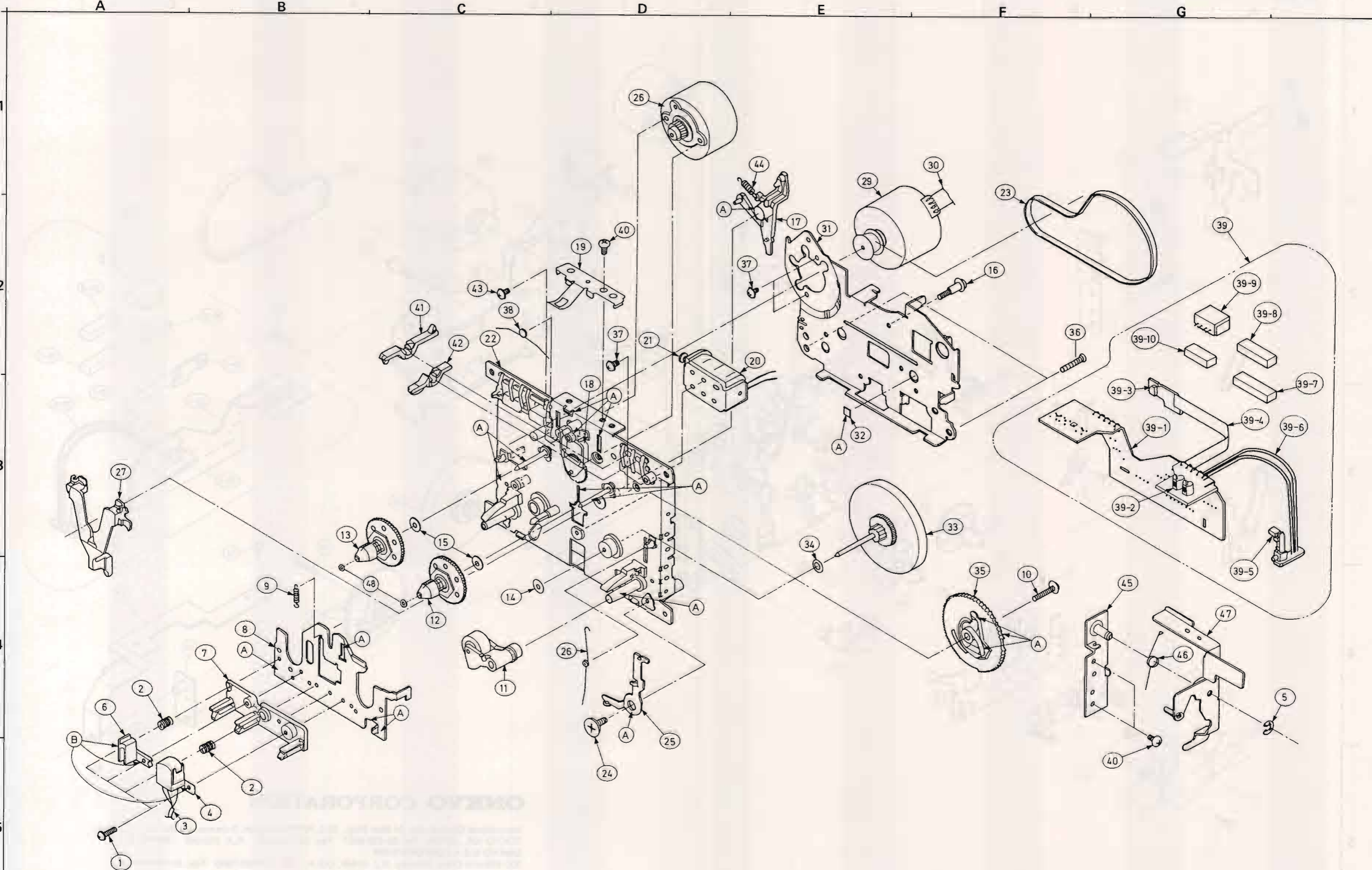

TAPE (2) MECHANISM-EXPLODED VIEW

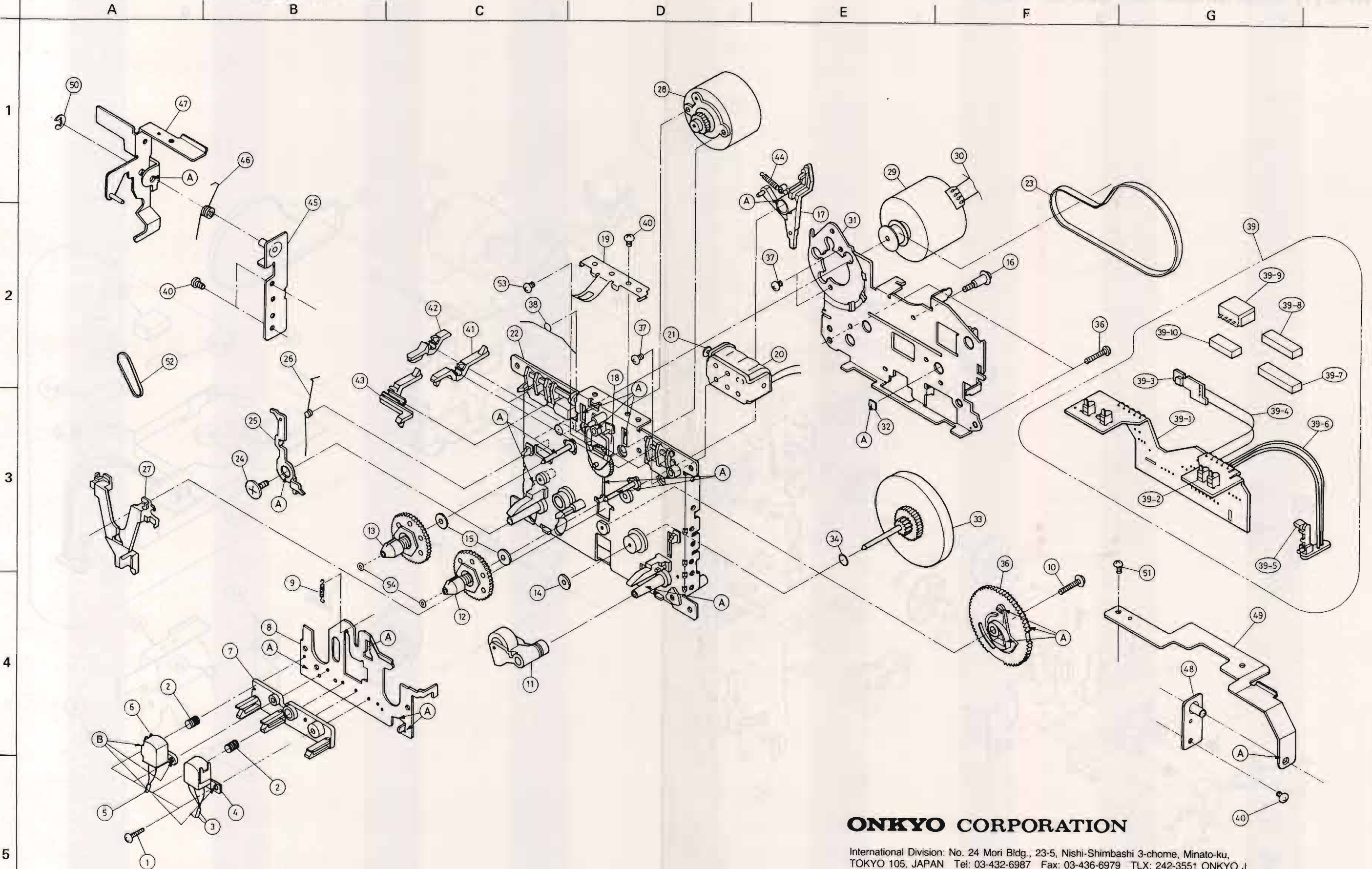

ONKYO CORPORATION

International Division: No. 24 Mori Bldg., 23-5, Nishi-Shimbashi 3-chome, Minato-ku,
 TOKYO 105, JAPAN Tel: 03-432-6987 Fax: 03-436-6979 TLX: 242-3551 ONKYO J
ONKYO U.S.A. CORPORATION
 200 Williams Drive, Ramsey, N.J. 07446, U.S.A. Tel: 201-825-7950 Fax: 201-825-8150